

CS10/20
SERIES

21-24.5 HP

SUB-COMPACT TRACTORS



Small But Mighty, Built For Your Needs



CS10 / CS20 SERIES

AGILE, FUEL-EFFICIENT TRACTORS DELIVERING POWERFUL, VERSATILE PERFORMANCE FOR ALL YOUR NEEDS

The Kioti CS10 and CS20 Series sub-compact tractors are engineered for big results, delivering reliable power and impressive fuel efficiency thanks to their 3-cylinder diesel engines. With a smooth, hydrostatic transmission and agile design, these tractors offer outstanding maneuverability and easy operation, making them ideal for mowing, landscaping, and hobby farming—even in tight spaces. The ergonomic layout ensures comfort during long hours, while robust construction promises years of dependable service with minimal maintenance. Whether you're a homeowner or hobby farmer, the CS10 and CS20 Series tractors deliver exceptional value and consistent performance in a user-friendly package.

**WE DIG
DIRT**

- Kioti 3-Cylinder In-Line Vertical, Water-Cooled Diesel Engine
- 21-24.5 HP
- Rear and Mid PTO
- Hydrostatic Transmission
- Twin HST Pedals
- 700 Pound 3-Point Lift Capacity
- Four-Wheel Drive
- Power Steering
- Tilt Steering Wheel (CS20 Series)
- Cruise Control (CS20 Series)
- Single Lever Joystick (CS20 Series)

CS10 / CS20 **SERIES**

BUILT TO PERFORM WITH FEATURES THAT GET IT DONE

Fuel Efficient Diesel Engine

The reliable, efficient 3-cylinder in-line vertical, water-cooled diesel engine delivers impressive performance and smooth operation, offering excellent power for a wide range of hobby farming and landscaping tasks.

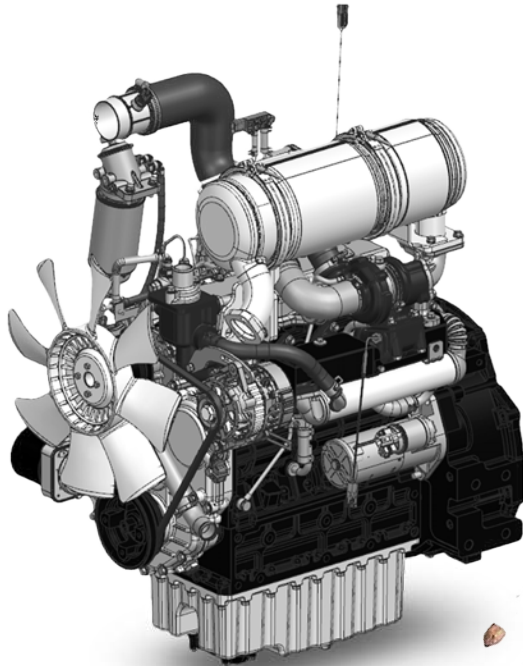

Proven Quality of Performance

KIOTI engines are known for exceptional performance and fuel efficiency. Backed by over 65 years of innovation, they meet rigorous global standards like EPA, CARB, and EEC certifications. Built for reliability and durability, these engines are a trusted choice for a wide range of demanding applications.



Hydrostatic Transmission

Powerful, reliable hydrostatic transmissions deliver efficiency and control. The easy-to-use twin pedals and 2-range transmission make operation smooth and safe.



Twin HST Pedals

Enables easy forward and reverse movement, with smooth acceleration and deceleration. The twin pedals simplify operation, reducing operator fatigue during long hours of work and repetitive tasks.



Rear & Mid PTO

Operate the rear and mid PTOs independently or simultaneously, reducing downtime to change implements and ensuring uninterrupted productivity.



Independent PTO

Designed for versatility and operator convenience, the independent PTO allows you to power your implements independently of your tractor's ground speed or transmission.



Single Lever Joystick (CS20 Series)

The joystick provides single-lever control for the loader functions. When released, it returns to neutral, stopping the loader in its current position. A float position allows the bucket to float freely over the ground surface.



Quick Attach & Detach Loader (CS20 Series)

The pinless design allows the operator to quickly remove or install the loader in minutes without needing to handle pins. The additional quick-attach system on the front makes switching attachments easy.



Impressive Lift Capacity

With a loader lift capacity of up to 1,062 lb. (482 kg.), the CS10 & CS20 deliver impressive strength for their class—ideal for reliable performance in landscaping, tilling, and material handling, all without stepping up to a larger machine.



3-Point Hitch

Features a robust Category I 3-point hitch with substantial lift capacity and precise control. The position control lever allows easy operation.



Four-Wheel Drive

Four-wheel drive provides increased traction and enhanced brake performance for seamless on- and off-road transitions.

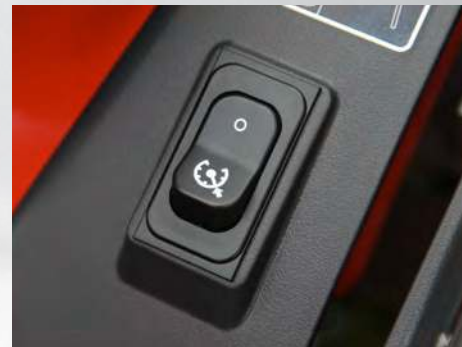

Cruise Control (CS20 Series)

Maintain consistent speeds effortlessly with the integrated cruise control. Perfect for tasks like mowing or spraying, simply set your desired speed and let the tractor do the work, reducing fatigue and ensuring a uniform finish.



CS10 / CS20 SERIES

BUILT FOR THE LAND – READY FOR ANYTHING



Efficient Fuel Capacity

The 6.7-gallon (25.5-liter) fuel tank delivers excellent fuel efficiency, allowing you to power through extended hours of work with fewer refueling stops.



Power Steering

Minimizes the effort needed to make tight, repetitive turns, enhancing driver comfort and control.



Tilt Steering Wheel (CS20 Series)

The tilt steering wheel is designed for maximum comfort, allowing operators to easily adjust to their ideal driving position for a smooth and relaxed experience, no matter the duration of the task.



Illuminated Dashboard

The dashboard illuminates when the engine starts. The digital gauge package includes a tachometer, fuel and temperature gauges, and a low fuel warning lamp.



KIOTI Connect Capable

Compatible with the KIOTI Connect app to track and manage your equipment's maintenance. You can leverage AI-powered features to get insights on agriculture and tractors.



Open Operator Station

With a sturdy platform and rubber floor mat, the operator station offers easy access to controls, convenient entry and exit, and protection from wear, spills, and scratches for lasting durability.



Streamlined Hood Design

The streamlined hood design improves visibility for the operator. A vertically opening hood allows easy access to the air filter, fluid service and inspection points, fuse box, and electrical components.



Foldable ROPS

The standard fold-down roll bar makes it quick and easy to maneuver in low clearance areas.



Ergonomic Operator Station

The ergonomically designed workstation ensures all operator controls are easily within reach. Featuring a seat belt and operator presence switch, the CS Series prioritizes safety for every operator.



Best-in-Class Headlights

Experience superior illumination with 55W headlight lamps, engineered to provide exceptional visibility for the operator, ensuring maximum safety and precision, even in low-light conditions.



12V Power Socket / USB Port (CS20 Series)

Power essential accessories or tools on the go with the built-in 12V power socket and convenient USB charging port. The CS10 Series includes only the power socket.



Fast Traveling Speeds

Tackle tasks with ease at speeds up to 10 mph (16 km/h)—ideal for covering ground quickly during property maintenance, yard work, or light agricultural jobs.





KIOTI

ATTACHMENTS

FRONT END LOADER

KIOTI SL2410 and SL2420 front-end loaders deliver impressive lift capacity, quick-attach convenience, and precise joystick control for CS10 and CS20 Series tractors.

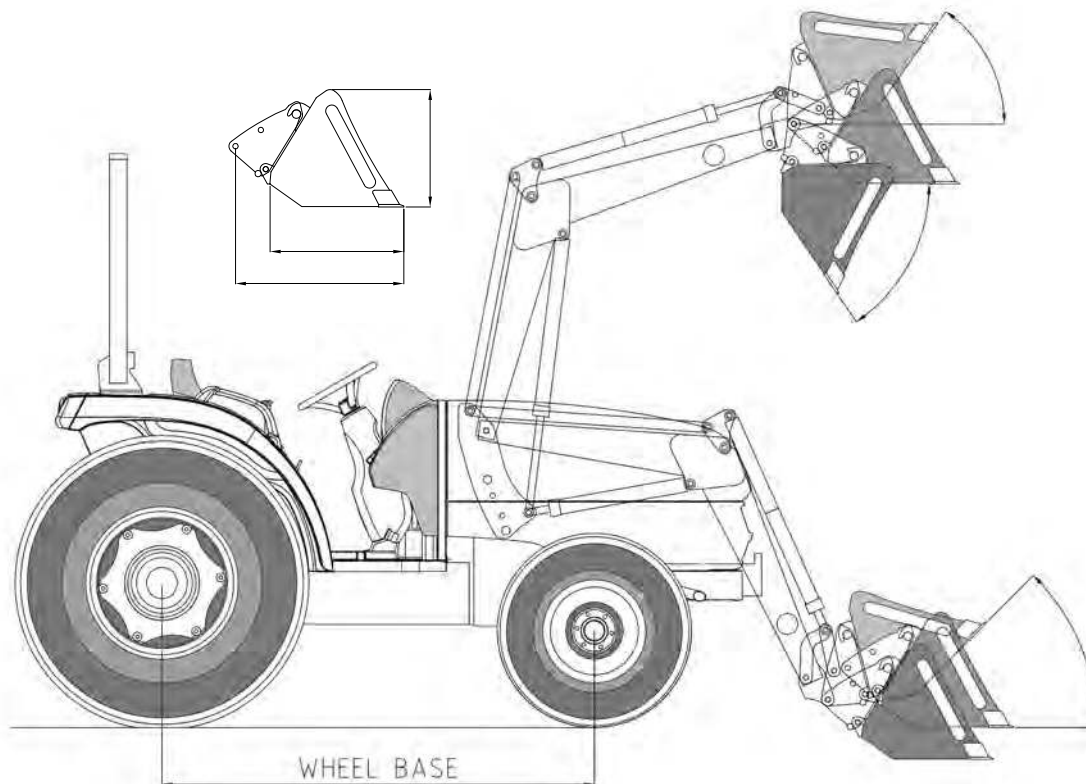

SPECIFICATIONS

| MODEL | | SL2410 | SL2420 |
|--|---------------------------|-----------------|-----------------|
| Compatible Models | | CS2210 / 2510 | CS2220 / 2520 |
| Maximum Lift Height (to Pivot Pin) | in. (mm) | 70.9 (1,800.9) | 73.7 (1,872.0) |
| Clearance w/ Bucket Level | in. (mm) | 67.6 (1,717.0) | 68.1 (1,729.7) |
| Clearance w/ Bucket Dumped | in. (mm) | 54.4 (1,381.8) | 54.8 (1,391.9) |
| Reach at Maximum Height | in. (mm) | 30.7 (779.8) | 29.7 (754.4) |
| Maximum Dump Angle | deg. | 45 | 38 |
| Reach w/ Bucket on Ground | in. (mm) | 53.1 (1,348.7) | 52.8 (1,341.1) |
| Maximum Rollback Angle | deg. | 27 | |
| Digging Depth Below Grade | in. (mm) | 4.4 (111.8) | 5.1 (129.5) |
| Overall Height (Carry Position) | in. (mm) | 41.5 (1,054.1) | 34.1 (866.1) |
| Depth of Bucket (to Back of Inner Shell) | in. (mm) | 17.5 (444.5) | 18.0 (457.2) |
| Height of Bucket | in. (mm) | 19.3 (490.0) | 19.0 (484.0) |
| Length of Bucket (to Pivot Pin) | in. (mm) | 21.5 (546.1) | 22.4 (568.9) |
| Lift Capacity to Full Height | lb. (kg) | 683.4 (310.0) | 1,062.3 (482.0) |
| Breakout Force (at Pivot Pins) | lb. (kg) | 1,435.2 (651.0) | 1,329 (603.0) |
| Bucket Rollback Force (at Ground Line) | lb. (kg) | 846.6 (384.0) | 904.0 (410.0) |
| Relief Valve Setting (Loader Control Valve) | psi (kg/cm ²) | 1,900.0 (133.6) | |
| Rated Flow (Tractor System) | gpm (L/min) | 3.5 (13.4) | 4.9 (18.7) |
| Bucket Size (QA) | in. (mm) | 48.0 (1,219.0) | |
| Bucket Capacity (Heaped) | cu. ft. (cu. m) | 6.7 (0.2) | |
| Approximate Weight (With Bucket) | lb. (kg) | 498.0 (225.9) | 573.0 (260.0) |

NOTE: specifications and design are subject to change without notice.

ATTACHMENTS



MID-MOUNT MOWER

The KIOTI SM2454 and SM2460 mid-mount mowers offer clean, precise cutting with durable decks, smooth operation, and easy height adjustment.

SPECIFICATIONS

| MODEL | SM2454 | SM2460 |
|-------------------------------------|-----------------------------|----------------|
| Compatible Models | CS10/CS20 Series | |
| Dischare Type | Side Discharge | |
| Cutting Width | in. (mm) 53.7 (1,364.0) | 60.0 (1,524.0) |
| Cutting Height | in. (mm) .8~3.8 (20.3~96.5) | |
| Transport Height | in. (mm) 6.0 (152.4) | |
| Gear Type | Spiral Bevel | |
| Number of Blades | 3 | |
| Blade Spindle Speed | rpm 2,888 | |
| Blade Tip Velocity | m/s 71.1 | 78.2 |
| Blade Length | in. (mm) 18.5 (470.0) | 20.4 (517.0) |
| Deck Thickness | in. (mm) 0.13 (3.3) | |
| Total Width | in. (mm) 69.3 (1,760.0) | 75.0 (1,905.0) |
| Total Length | in. (mm) 35.7 (908.0) | 37.9 (962.0) |
| Total Height | in. (mm) 10.5 (267.0) | |
| Drive Type | U-Joint & V-Belt | |
| Lifting Type | 3 Point Hitch Links | |
| Loader/Backhoe Compatibility | Yes | |

NOTE: specifications and design are subject to change without notice.

BACKHOE

The SB2410L and SB2420 backhoes deliver powerful digging performance with easy attachment, responsive controls, and durable construction for tough jobs.

SPECIFICATIONS

| MODEL | SB2410L | SB2420 |
|--|--|--|
| Compatible Models | CS2210 / 2510 | CS2220 / 2520 |
| Bucket Sizes | in. (mm) 8.0 (203.0) / 12.0 (305.0) / 16.0 (406.0) | 8.0 (203.0) / 12.0 (305.0) / 16.0 (406.0) / 24.0 (609.0) |
| Digging Depth (Two Foot Flat Bottom) | in. (mm) 72.8 (1,850.0) | |
| Reach from Center Line of Swing Pivot | in. (mm) 105.7 (2,684.0) | |
| Loading Height (Bucket at 60°) | in. (mm) 59.1 (1,500.0) | |
| Maximum Leveling Angle | deg. 8 | |
| Swing Arc | deg. 150 | |
| Transport Height (Maximum) | in. (mm) 68.1 (1,729.0) | |
| Transport Overhang | in. (mm) 41.3 (1,050.0) | |
| Bucket Rotation | deg. 165 | |
| Stabilizer Spread (Down Position) | in. (mm) 78.0 (1,981.2) | |
| Stablizier Spread (Up Position) | in. (mm) 54.0 (1,371.6) | |
| Angle of Departure | deg. 14.5 | 20.0 |
| Shipping Weight (Without Bucket) | lb. (kg) 635.0 (288.0) | |
| Bucket Digging Force | lb. (kg) 2,105.0 (954.8) | |
| Dipperstick Digging Force | lb. (kg) 1,183.0 (536.6) | |
| Operating Pressure | psi (bar) 1,885.0 (130.0) | |

NOTE: specifications and design are subject to change without notice.





SPECIFICATIONS

| MODEL | | CS2210H | CS2220H | CS2510H | CS2520H | |
|-----------------------------------|--------------|---|-----------------|-----------------|-----------------|----------------|
| ENGINE | | | | | | |
| Model | | 3C100LWH-U3 | | 3C100LFH-U2 | | |
| Type | | KIOTI 3-Cylinder In-Line Vertical, Water-Cooled Turbo Diesel Engine | | | | |
| Engine Gross | HP (kW) | 21.0 (15.6) | | 24.5 (18.3) | | |
| PTO @ Rated PTO rpm | HP (kW) | 16.3 (12.2) | | 18.5 (13.8) | | |
| Displacement | cu. in. (cc) | 61.5 (1,007.0) | | | | |
| Rated Revolution | rpm | 3,200 | | | | |
| Fuel Tank Capacity | gal. (ℓ) | 6.7 (25.5) | | | | |
| DRIVE TRAIN | | | | | | |
| Transmission | | Hydrostatic | | | | |
| Speeds | | Infinite, 2 Range | | | | |
| Differential Lock | | Rear Standard | | | | |
| Brake | | Wet Multi Disc | | | | |
| PTO Type | | Independent | | | | |
| Rear PTO (Standard) | rpm | 540 | | | | |
| Mid PTO (Optional) | rpm | 2,000 | | | | |
| 4WD Type | | Mechanical Engagement | | | | |
| HYDRAULIC SYSTEM | | | | | | |
| Pump | | Gear | | | | |
| Pump Capacity (Max flow rate) | | 6.5 (24.6) | 7.0 (26.4) | 6.5 (24.6) | 7.0 (26.4) | |
| 3-Point Hitch | | Category I | | | | |
| Maximum Lift Capacity* | lb. (kg) | 700 (318) | | | | |
| Hydraulic Lift Control System | | Position | | | | |
| Steering | | Hydrostatic Power Steering | | | | |
| TIRE SIZE | | | | | | |
| Front AG. (Turf, Industrial) | | 18×8.5-10 (18×8.5-10) | | | | |
| Rear AG. (Turf, Industrial) | | 26×12.00-12 (26×12.00-12) | | | | |
| TRAVELING SPEEDS (Max) | | | | | | |
| Forward | mph (kph) | 0~10.3 (0~16.6) | 0~9.6 (0~15.4) | 0~10.3 (0~16.6) | 0~9.6 (0~15.4) | |
| Reverse | mph (kph) | 0~7.0 (0~11.2) | 0~6.6 (0~10.6) | 0~7.0 (0~11.2) | 0~6.6 (0~10.6) | |
| DIMENSIONS | | | | | | |
| Overall Length (incl. 3-pt hitch) | in. (mm) | 99.3 (2,523.0) | | | | |
| Overall Width (min. tread) | in. (mm) | 46.7 (1,185.0) | 45.9 (1,168.0) | 46.7 (1,185.0) | 45.9 (1,168.0) | |
| Overall Height (From Top of ROPS) | in. (mm) | 87.6 (2,226.0) | | | | |
| Wheelbase | in. (mm) | 55.1 (1,400.0) | | | | |
| Min. Ground Clearance | in. (mm) | 6.4 (162.0) | | | | |
| Tread | Front (AG) | in. (mm) | 45.3 (1,150.0) | 46.0 (1,168.0) | 45.3 (1,150.0) | 46.0 (1,168.0) |
| | Rear (AG) | in. (mm) | 46.7 (1,185.0) | 46.0 (1,168.0) | 46.7 (1,185.0) | 46.0 (1,168.0) |
| Min. Turning Radius (With Break) | ft. (m) | 8.2 (2.54) | | | | |
| Weight with AG. Tires | lb. (kg) | 1,485.0 (673.6) | 1,554.0 (705.0) | 1,485.0 (673.6) | 1,554.0 (705.0) | |

* @ 24" aft. of hitch

NOTE: specifications and design are subject to change without notice.

STANDARD EQUIPMENT

- Rear PTO
- Mid PTO
- Single Lever Joystick (CS20 Series)
- Cruise Control (CS20 Series)
- Tilt Steering Wheel (CS20 Series)
- USB Port (CS20 Series)
- 12V Power Socket
- Power Steering
- Parking Brake
- PTO Shield
- Headlights
- Warning/Signal Lamps
- Cup Holder
- Horn
- SMV Sign

OPTIONAL EQUIPMENT

- Front Hydraulic Valve (CS10 Series)
- Rear Hydraulic Valve
- Rear Working Lights
- Cruise Control (CS10 Series)
- Front Weight (60 lbs)
- Side View Mirror
- Canopy Kit
- Grill Guard
- Armrest
- Front Towing Hook
- Hydraulic Filter Guard
- Rear Wheel Weight
- Field Option Cab



Daedong - USA, Inc.
KIOTI Tractor Division
 6300 KIOTI Drive, Wendell, NC 27591 USA
 Toll free 877-GO-KIOTI Fax 919-374-5001
 Web www.KIOTI.com

Dealer Imprint Area

CS30
SERIES

21-24.5 HP

SUB-COMPACT TRACTORS



Ride in Comfort, Work with Power and Ease





C530 SERIES

THE SUB-COMPACT TRACTOR THAT DELIVERS COMFORT AND CAPABILITY FOR EVERY SEASON.

Revolutionize your land management experience with a sub-compact tractor available in both ROPS and factory-installed, climate-controlled cab models. Whether you prefer open-air operation or all-season comfort, this game-changing tractor sets a new standard for versatility, convenience, and productivity—boasting the highest torque in its class. With powerful performance and year-round capability, you'll tackle even the toughest tasks with ease. Say goodbye to limits and hello to a more efficient, enjoyable experience working the land.



WE DIG DIRT

- Premium Factory Installed Cab (Cab Model)
- Heat and Air Conditioning (Cab Model)
- KIOTI 1.2 L / 3 Cylinder Diesel Engine
- KIOTI Connect Capable
- Hydrostatic Transmission
- Mid and Rear PTO
- Digital Instrument Panel
- Improved Fuel Efficiency
- Improved Lever Layout



CS30 SERIES

EXPERIENCE UNPARALLELED COMFORT, MAXIMUM PERFORMANCE AND UNMATCHED EFFICIENCY

Fuel Efficient Diesel Engine

The KIOTI 1.2L 3-cylinder water-cooled diesel engine delivers 21 or 24.5 horsepower with class-leading torque, giving you the strength and efficiency to power through any task. With a 22% larger displacement than previous models, it provides reliable performance for chores of any size, without sacrificing fuel economy.

Proven Quality and Performance

KIOTI engines are known for exceptional performance and fuel efficiency. Backed by over 65 years of innovation, they meet rigorous global standards like EPA, CARB, and EEC certifications. Built for reliability and durability, these engines are a trusted choice for a wide range of demanding applications.

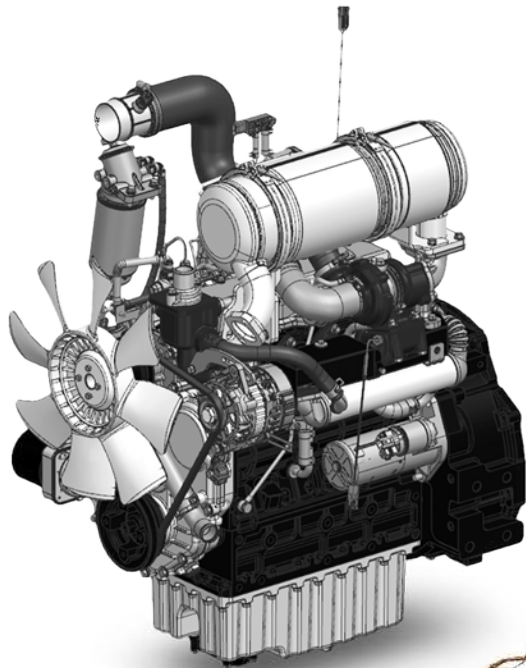

Mid and Rear PTO

Operate the rear and mid PTO's independently or simultaneously reducing downtime to change implements ensuring uninterrupted productivity.



Factory Installed Cab (Cab Model)

Enjoy unmatched comfort with a factory-installed, climate-controlled cab featuring heat and ac, premium suspension seat, wide operator station, increased storage and reduced noise and vibration.



Improved Lever Layout and Operability

Enjoy improved control and comfort with an ergonomic design for a natural fit and intuitive operation. Our levers ensure precision and confidence, making your work more comfortable and efficient.



Four-Wheel Drive

Four-wheel drive comes standard, providing enhanced traction and stability, and is easily engaged with a simple push-pull lever, ensuring quick and effortless control over the most rugged terrain.



Twin HST Pedals

Twin HST pedals enable easy forward and reverse movement, with smooth acceleration and deceleration. The dual pedals simplify operation, reducing operator fatigue during long hours of work and repetitive tasks.



Illuminated Digital Instrument Panel

The instrument panel provides critical information at a glance, including PTO engagement, vehicle information, fuel level, notifications, and alerts.



Projection Head and Working Lamps (Cab Models)

The LED projection head and working lamps pierce the darkness, casting a wide, clear beam that illuminates your field for safe, precise maneuvering even after sunset.



Power with Tilt Steering

Minimizes the effort required to make tight, repetitive turns. The steering wheel tilts with the simple push of a lever, allowing easy adjustment to fit the operator's needs.



Integrated Multimedia Display (Optional Cab Model)

Elevate your entertainment with our multimedia display, boasting vivid audio/video and superior sound quality. Pair it with a separately purchased high-quality camera for an immersive experience, enhanced by a seamless AV multimedia deck for top-tier performance and connectivity.



Rear View Camera (Optional Cab Model)

Revolutionize your workday with the rear view camera, eliminating blind spots and enhancing convenience and precision. With a clear, real-time view, operators can confidently perform three-point maneuvers and reverse with ease.



CS30 ROPS SERIES BUILT WITH COMFORT IN MIND



Cruise Control

Maintain consistent speeds effortlessly with the integrated cruise control. Perfect for tasks like mowing or spraying, simply set your desired speed and let the tractor do the work, reducing fatigue and ensuring a uniform finish.



HVAC Climate Control (Cab Model)

Our advanced HVAC system provides optimized heating and cooling, ensuring a comfortable cabin year-round. Enjoy reliable cooling in summer and warmth in winter. Engineered for efficiency and durability, this system enhances operator comfort and productivity.



Deluxe Suspension Seat (Cab Model)

The Deluxe Suspension Seat is engineered to deliver comfort for the operator by absorbing shocks and vibrations, minimizing the impact of rough surfaces and ensuring a smooth ride.



Swivel Seat for Backhoe Operation (Optional)

The swivel feature allows the operator to rotate the seat towards the rear of the tractor, facilitating in-cab operation of the backhoe when installed.



Drive-Over Deck

Offers a seamless and efficient mounting experience, allowing you to easily mount the mid mower by simply driving over it. This innovative design streamlines setup, eliminating side insertion and getting you to work faster with minimal effort.



Front and Rear Wipers (Cab Model)

Standard front double arm wiper (optional rear single arm wiper) keeps your view crystal clear, battling both rain and dust. Their optimized placement ensures the operator's vantage point stays clean and uncompromised.



Electric / Hydraulic Thumb (Optional)

Designed for ease of use, this feature allows for precise and responsive control of the hydraulic thumb directly through the joystick, allowing you to accomplish more in less time.



Rear Differential Lock

The lever easily engages the differential, ensuring optimal traction in slippery conditions like uneven or muddy terrain.





INCREASED PRODUCTIVITY

Improved performance, work faster & more efficiently



IMPROVED EFFICIENCY

Controls within easy reach for convenience



CAB & ROPS MODELS

Weather protection or open-air flexibility



Enhanced Warranty

Benefit from peace of mind, knowing that your equipment is protected by Kioti's standard 4 year, unlimited hour warranty



SERIES
CS230





KIOTI Connect Capable

KIOTI Connect is an intuitive app that provides real-time insights, maintenance tracking, and remote diagnostics, keeping you connected to your machine like never before.



Rubber Floor Mats

Rubber floor mats are designed to protect the base of your tractor from dents and scratches, ensuring long-lasting durability. Additionally, these mats are easy to clean, allowing for quick removal of dirt and debris.



Standard Quick Attach

The Quick Attach feature makes switching tasks easy, with minimal effort and maximum convenience. Left and right levers allow you to effortlessly install and remove attachments from the loader quickly & efficiently.



Easy Loader Attachment Access

Enjoy the convenience and safety of controlling the loader quick release right from your seat, staying comfortable and efficient without the hassle of repeatedly getting on and off the tractor.



USB Charging Port with AUX/Stereo (Cab Model)

Stay connected and entertained with the built-in USB charging port and AUX/stereo system. Connect your phone to the cabin speakers via AUX, or upgrade to optional Bluetooth stereo or audio den for enhanced music and streaming capabilities.



Class-Leading Torque

Boasting exceptional power in a compact footprint, the CS Series delivers standout performance across the lineup. The CS2530 produces 51.63 lb.-ft. of class-leading torque and 24.5 horsepower, while the CS2230 delivers 46.47 lb.-ft. of torque and 21 horsepower, giving operators the power to tackle mowing, tilling, landscaping, and hauling with ease.



Self-Leveling Loader (Optional)

Maintains the desired bucket angle when lifting and lowering, preventing the need to manually position the bucket throughout the lift/lower cycle to keep your material in the bucket. This can increase productivity while adding a layer of safety to your worksite.



Backhoe Compatible Cabin (Cab Model)

Allows for smooth transitions between driving and digging, with a removable rear glass and back panel, quickly transition from tractor to backhoe operations for instant access to controls. This design minimizes downtime and maximizes productivity.



KUBOTA

ATTACHMENTS

FRONT END LOADER SPECIFICATIONS

| MODEL | | SL2530 (Non-Self Leveling) | SL2530 (Self Leveling*) |
|--|------------------------------------|----------------------------|---------------------------|
| Maximum Lift Height (to Pivot Point) | in. (mm) | 70.9 (1,800.0) | 71.1 (1,807.0) |
| Clearance w/Bucket Dumped (@ 45°) | in. (mm) | 50.4 (1,280.2) | 51.6 (1,310.0) |
| Reach at Maximum Height | in. (mm) | 28.3 (718.0) | 27.4 (695.0) |
| Reach w/Bucket on Ground | in. (mm) | 54.2 (1,377.0) | 54.4 (1,382.0) |
| Maximum Rollback Angle | deg. | 27 | 42 |
| Digging Depth Below Grade | in. (mm) | 8.1 (205.0) | 7.5 (190.0) |
| Overall Height (in Carry Position) | in. (mm) | 43.4 (875.0) | 35.6 (905.0) |
| Depth of Bucket (to Back of Inner Shell) | in. (mm) | 17.0 (432.0) | 17.0 (432.0) |
| Height of Bucket | in. (mm) | 18.6 (473.0) | 18.6 (473.0) |
| Length of Bucket (to Pivot Pin) | in. (mm) | 22.0 (559.0) | 22.0 (559.0) |
| Lift Capacity to Full Height (at Pivot Pins) | lb. (kg) | 870.8 (395.0) | 912.7 (414.0) |
| Breakout Force (at Pivot Pins) | lb. (kg) | 1,298.5 (589.0) | 1,280.9 (581.0) |
| Relief Setting (Loader Control Valve) | psi (kgf/cm ²) | 1,849 ~ 1,920 (130 ~ 135) | 1,849 ~ 1,920 (130 ~ 135) |
| Bucket Size (QA) | in. (mm) | 48.0 (1,219.2) | 48.0 (1,219.2) |
| Bucket Capacity (Heaped) | ft. ³ (m ³) | 6.70 (0.19) | 6.70 (0.19) |

*Mechanical self leveling (optional).

MID-MOUNT MOWER SPECIFICATIONS

| MODEL | | SM2554 | SM2560 |
|------------------------------|----------|--------------------------|----------------------|
| Mounting Method | | Suspended Linkage | Suspended Linkage |
| Adjustment of Cutting Height | | 7 Step (0.5"/ Step) | 7 Step (0.5"/ Step) |
| Cutting Width | in. (mm) | 53.9 (1,368.0) | 60.0 (1,524.0) |
| Cutting Height | in. (mm) | 1.0 - 4.0 (25.4 - 101.6) | 1 - 4 (25.4 - 101.6) |
| Weight | lb. (kg) | 249.0 (112.9) | 254.0 (115.2) |
| Deck Thickness | in. (mm) | 0.1 (3.2) | 0.1 (3.2) |
| Blade Spindle Speed | rpm | 2,805 | 2,805 |
| Blade Tip Velocity | m/s | 69.2 | 75.2 |
| Blade Length | in. (mm) | 18.5 (470.0) | 20.4 (517.0) |
| Number of Blades | | 3 | 3 |
| Total Length | in. (mm) | 35.7 (908.0) | 37.9 (962.0) |
| Total Width | in. (mm) | 69.3 (1,760.0) | 73.4 (1,865.0) |
| Total Height | in. (mm) | 10.5 (267.0) | 10.7 (273.0) |
| Auto Connector Link KIT | in. (mm) | N/A | Optional |
| Auto Joint KIT | in. (mm) | N/A | Optional |

BACKHOE SPECIFICATIONS

| MODEL | | SB2530 |
|---------------------------------------|-----------|---------------------------------------|
| Bucket Sizes | in. (mm) | 8.0 (203.0) 12.0 (304.0) 16.0 (406.4) |
| Digging Depth (Two Foot Flat Bottom) | in. (mm) | 72.4 (1,840.0) |
| Reach from Center Line of Swing Pivot | in. (mm) | 105.0 (2,668.0) |
| Loading Height (Bucket at 60°) | in. (mm) | 59.4 (1,510.0) |
| Maximum Leveling Angle | deg. | 8 |
| Swing Arc | deg. | 150 |
| Transport Height (Maximum) | in. (mm) | 68.5 (1,739.0) |
| Transport Overhang | in. (mm) | 41.3 (1,050.0) |
| Bucket Rotation | deg. | 165 |
| Stabilizer Spread (Down Position) | in. (mm) | 78.0 (1,981.0) |
| Stabilizer Spread (Up Position) | in. (mm) | 54.0 (1,372.0) |
| Angle of Departure | deg. | 17 |
| Shipping Weight (Without Bucket) | lb. (kg) | 613.0 (278.0) |
| Bucket Digging Force | lb. (kgf) | 2,105.4 (955.0) |
| Dipperstick Digging Force | lb. (kgf) | 1,183.9 (537.0) |
| Operating Pressure | psi (bar) | 1,886.0 (130.0) |

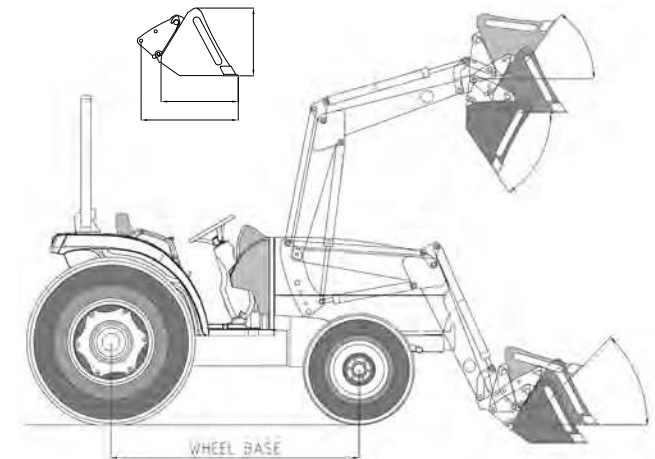

* Specifications and design are subject to change without notice.

SPECIFICATIONS

| MODEL | | CS2230H | CS2530H | CS2530HC |
|---|--------------|---------------------------------------|---------|-------------------|
| ENGINE | | | | |
| Model | | KIOTI 3L123 | | |
| Type | | KIOTI 3 Cylinder, Water-Cooled Diesel | | |
| Engine Gross | HP (kW) | 21.0 (15.7) | | 24.5 (18.3) |
| PTO | HP (kW) | 16.7 (12.5) | | 19.3 (14.3) |
| Displacement | cu. in. (cc) | 75.2 (1,233) | | |
| Rated Revolution | rpm | 3,000 | | |
| Fuel Tank Capacity | gal. (ℓ) | 6.6 (25.5) | | |
| DRIVE TRAIN | | | | |
| Transmission | | 2 Range Hydrostatic | | |
| Speeds | | Infinite | | |
| Differential Lock | | Rear Standard | | |
| Brake | | Wet Disc | | |
| PTO | | Independent | | |
| Rear PTO | rpm | 540 | | |
| Mid PTO | rpm | 2,200 | | |
| 4WD Type | | Mechanical | | |
| HYDRAULIC SYSTEM | | | | |
| Pump | | Open Center | | |
| Pump Capacity (max flow rate) | GPM (lpm) | Steering 2.03 (7.7) / Imp. 4.9 (18.7) | | |
| 3-Point Hitch | | Category I | | |
| Maximum Lifting Capacity* | lb. (kg) | 700.0 (317.5) | | |
| Hydraulic Lift Control System | | Mechanical | | |
| No. of Standard Remote Valves (Rear) | | 1 (Optional) | | |
| Tire Size | | | | |
| Front AG. | | 18 x 8.5 - 10 | | |
| Rear AG. | | 26 x 12 - 12 | | |
| TRAVEL SPEED | | | | |
| Forward | mph (km/h) | 0 ~ 8.99 mph (0 ~ 14.47 kph) | | |
| Reverse | mph (km/h) | 0 ~ 6.15 mph (0 ~ 9.90 kph) | | |
| DIMENSIONS | | | | |
| Overall Length w/o front weight & w/ 3-pt hitch | in. (mm) | 102.9 (2,615.0) | | 107.1 (2,720.0) |
| Overall Width (min. tread) | in. (mm) | 48.8 (1,240.0) | | 50.0 (1,270.0) |
| Overall Height | in. (mm) | 87.6 (2,224.0) | | 82.6 (2,100.0) |
| Wheelbase | in. (mm) | 55.1 (1,400.0) | | |
| Min. Ground Clearance | in. (mm) | 6.4 (162.0) | | |
| Min. Turning Radius (With Brake) | in. (mm) | 100.0 (2,540.0) | | |
| Weight with AG. Tires | lb. (kg) | 1,735.0 (787.0) | | 2,403.0 (1,090.0) |

* @ 24" aft of hitch

NOTE: Specifications and design are subject to change without notice.

STANDARD EQUIPMENT

- Power Steering
- Tilt Steering
- Rear Differential Lock
- Rear PTO
- Mid PTO
- Wet Multi Disc Brakes
- Joystick Valve
- 4-Wheel Drive
- Cruise Control
- PTO Shield
- SMV Sign
- Parking Brake
- Headlights
- Warning / Signal Lamps
- 12V Power Outlet & USB Socket
- KIOTI Connect Capable
- Horn
- Fixed Drawbar
- Cup Holder
- Power & USB Socket
- Foldable ROPS (ROPS Models)
- Side View Mirrors (Cab Model)
- Rear Window Defrost (Cab Model)
- Rear Wheel Weights (Cab Model)
- Suspension Seat (Cab Model)
- Seat Arm Rests (Cab Model)
- HVAC (Cab Model)
- Rear View Mirror (Cab Model)
- Front Wiper (Cab Model)
- Sun Visor (Cab Model)
- Front Work Lights (Cab Model)

OPTIONAL EQUIPMENT

- 3rd Function Joystick
- Front Grille Guard
- Rear Work Lights
- Hydraulic Filter Guard
- Towing Hook
- Remote Hydraulic Valve
- Front Hitch
- Front Weight
- Rear Weight
- Sun Canopy (ROPS Models)
- Seat Arm Rests (ROPS Models)
- Beacon Light (Cab Model)
- 7 Pin Socket (Cab Model)
- Bluetooth Radio (Cab Model)
- Rear View Mirror (Cab Model)
- LCD Monitor (Cab Model)
- Rear Window Wiper (Cab Model)
- Back Up Camera (Cab Model)



Daedong - USA, Inc.
KIOTI Tractor Division
 6300 KIOTI Drive, Wendell, NC 27591 USA
 Toll free 877-GO-KIOTI Fax 919-374-5001
 Web www.KIOTI.com

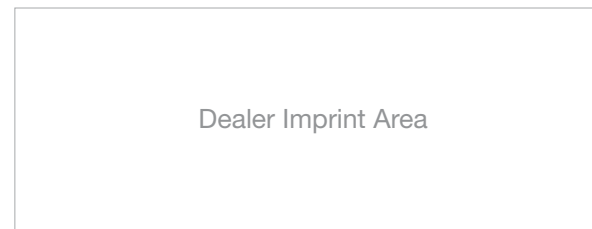

Dealer Imprint Area